



ECpvX Cluster

User manual

Document change log	4
Introduction	5
ECweb	7
Connecting to ECweb with Internet Explorer or Pale Moon browser on PC/laptop	7
Connecting to ECweb using any other browser or mobile device	7
Troubleshooting	8
Navigating the ECweb	9
Control	11
IP configuration	11
Internal clock	11
NTP synchronization	11
Manual time adjustment	12
Email client	13
Account	13
Automatic email transmission	13
FTP client	14
FTP server	14
Automatic FTP transfer	15
ECpvX Cluster server access	15
ECpvX FTP server	15
ECpvX Telnet server	16
ECpvX web server (ECweb)	17
Identifiers	18
ECpvX information	18
Project details	18
Password scheme	19
Passwords	20
Permissions	21
License & Extras	22
Search online	22
Search on USB	22
Metrics	23
Backups	24
Application	25
Settings	26
RS485 COM ports	26
Battery	28
Measurement	28
SOC Balancing	29
DOD thresholds	30

Counters	30
Inverter	32
RTU	32
TCP	33
Advanced Inverter command setup	34
Battery ratings	34
DOD settings	35
IO modules	36
Analogue input/output	37
Alarms	38
COM2 slave	39
COM3 slave	39
TCP slave	40
Common master communication	40
Proprietary modbus pages	41
Logs	42
Local logs with transmission via mail/ftp	42
EClogic	43
Builder	44
Example (Ecpv example)	45
Linker	46
Example continued (Ecpv example)	46
General Purpose Hysteresis	47
IO	48
Command timers	48
Command panel	49
Monitoring	50
Command panel	50
IO module data	51
Service Tool	52
Identifiers	53
Application	53
Settings	55
IO configuration	55
AIO	58
Modbus Tester	59
Client trace	60
Telnet server	60
Boot	61
Identifiers	62
SW update	62
Application	63

Document change log

2022-09-07	First version
2023-05-08	Updated for version 1.02.0

Introduction

The ECpvX Cluster from ENcombi is capable of controlling a stack of ECpvX slave controllers. The Cluster will receive references from ECpvX master and distribute references to each slave controller individually. The reference to the ECpvX slave will be calculated in terms of Online generating capacity and Online charging capacity. Examples will be shown in the specific chapter regarding setup.

The production of each ECpvX slave/battery inverter is controlled seamlessly via a communication interface to the ECpvX slave. This interface can be either via Modbus RTU running on serial RS485 line or via Modbus TCP running on ethernet.

The interface between the cluster and ECpvX are pre-embedded and are enabled merely by parameter setting.

All configuration and real time monitoring of the ECpvX Cluster is done by connecting with a standard web browser to its built-in webserver (ECweb). Comprehensive help texts guide you through the configuration setup. ECweb can run on any device featuring a web browser. Use for instance a panel PC as a local HMI. A laptop or portable device which will give you monitoring and control capabilities even from remote if connectivity to the ECpvX Cluster is in place.

It is not mandatory for the control and monitoring of the ECpvX to have a HMI or laptop connected to ECweb. It is required for commissioning of the ECpvX Cluster only.

The ECpvX Cluster can make a local event log file on an SD card or USB memory stick. This log can be sent to the customer ftp server or sent to the customer mail account.

Below schematics are examples of how the ECpvX Cluster is fitted into and interconnected to its surrounding environment.

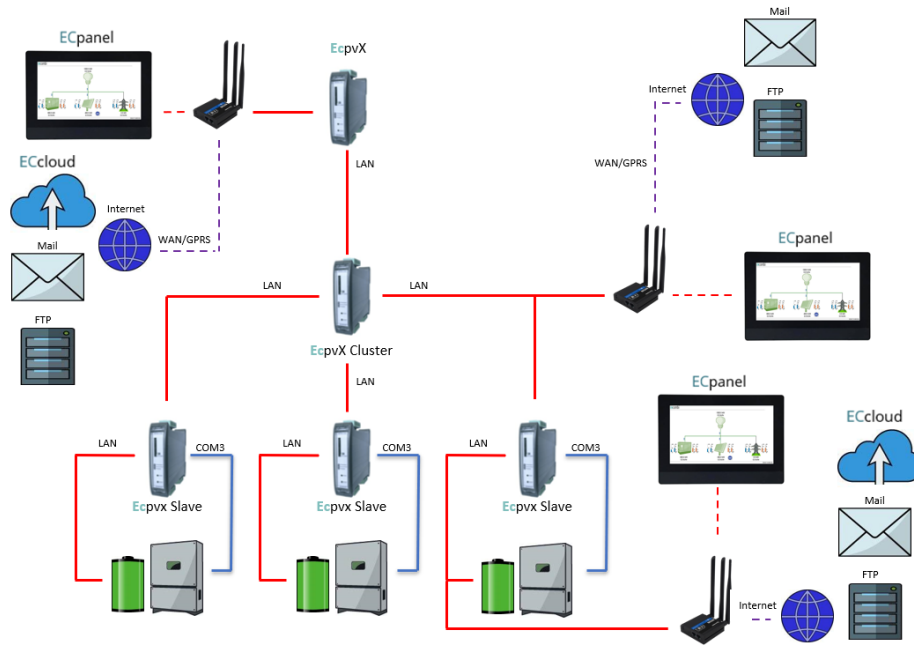

ECweb

ECweb is the built-in webserver of the ECpvX Cluster. All configuration and real time monitoring of the ECpvX Cluster is done via ECweb. Connection to ECweb is done with a standard web browser

Using a laptop/PC and Internet Explorer browser running on Java is the best option for connecting to ECweb. Other browsers and mobile devices can be used as well.

Connecting to ECweb with Internet Explorer or Pale Moon browser on PC/laptop

Java from oracle must be installed on PC/laptop. Java can be downloaded from the link below. Note that either the Internet Explorer or the Pale Moon browser must be used for the download.

[Java download](#)

1: Type in IP address of the ECpvX Cluster in the browser command line.

Default IP address is:

192.168.1.101.

2: Type in login credentials when prompted.

Default login credentials are:

user: web_user0

password: web_password0

3: Accept/Ignore all warnings populated.

4: If tiles on the front page are out of order, click on the page and they will fall into place. If any Icons are missing on the tiles, restart the browser and start over.

Connecting to ECweb using any other browser or mobile device

For all other browsers on PC/laptop or from any browser on mobile devices.

1: Type in IP address/webvisu.html in the browser command line.

Default IP address is:

192.168.1.101.

2: Type in login credentials when prompted.

Default login credentials are:

user: web_user0

password: web_password0

Troubleshooting

If connection can't be established verify that:

1. ECpvX Cluster is powered up and running. ECpvX Cluster must have 24VDC (+/- 15%) supply voltage. The green Power and the green Run LEDs in the front of the ECpvX must both be illuminated. Note that a two low supply voltage can result in a situation where sufficient voltage is present to power up the ECpvX Cluster but not to run the program. In this case the Power LED is illuminated but the Run LED. When powering up the ECpvX Cluster the Power LED will light up first and the Run LED will come approximately 30s after when ECpvX is initialized and the program is up and running.
2. Your laptop must be on the same subnet as the ECpvX Cluster. Even though you have an ethernet cable going directly from your laptop to the ECpvX you still need to make sure that your laptop is provided with a suitable IP address. In the case where the default IP address of the ECpvX Cluster 192.168.1.101 is kept a suitable IP address for your laptop would be 192.168.1.x, where x is a number in the range [2;249] excluding "101" as this is used by the ECpvX Cluster itself.
3. Once the IP of your laptop is in place you must be able to ping the ECpvX Cluster. This can be done by opening a command prompt and writing the command "ping xxx.yyy.zzz.www" where xxx.yyy.zzz.www is the IP address of the ECpvX Cluster as shown below. First when the ECpvX Cluster replies to the command it is verified that your laptop and the ECpvX Cluster can see each other on the network and you can connect to ECweb using the browser as described above.

```
C:\Users\Claus>ping 192.168.1.101

Pinging 192.168.1.101 with 32 bytes of data:
Reply from 192.168.1.101: bytes=32 time=15ms TTL=255
Reply from 192.168.1.101: bytes=32 time=25ms TTL=255
Reply from 192.168.1.101: bytes=32 time=1ms TTL=255
Reply from 192.168.1.101: bytes=32 time=11ms TTL=255

Ping statistics for 192.168.1.101:
    Packets: Sent = 4, Received = 4, Lost = 0 (0% loss),
    Approximate round trip times in milli-seconds:
        Minimum = 1ms, Maximum = 25ms, Average = 13ms
```

Navigating the ECweb

The first page to be displayed after an initial welcome page when connection is established is the front page of ECweb.

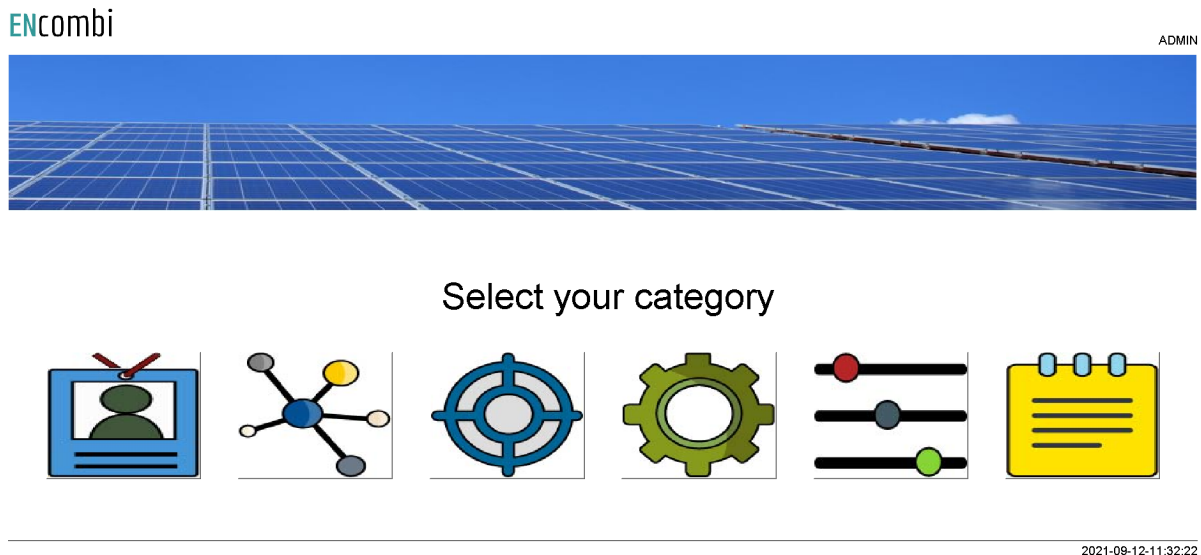

Whenever navigating around the ECweb you can always return to this page by clicking the ENcombi logo in the upper left corner.

In the upper right corner you can see the current access login level. Find more information about this in the chapter revolving password scheme.

In the lower left corner ECpvX Cluster will display any info and warning messages it wants to communicate to the user. Some messages will clear themselves automatically. Others demand user action to be acknowledged first. In that case a dedicated button with a garbage can symbol will be presented alongside the messages. Furthermore when changing certain settings etc. a reboot of the ECpvX Cluster is required before the changes take effect. This will be communicated in the message as well and a dedicated button with refresh symbol will be presented alongside with the messages.

In the lower right corner is the internal clock of the ECpvX Cluster displayed.

In the lower center a total of six menu tiles are available. These are from the left:

1. "Identifiers" gives access to overview of SW version installed and extras present in the ECpvX Cluster as well as set up of project details (name, location etc.), password scheme etc.
2. "EClogic" provides the possibility of making project specific logical expressions when required. That could be for linking physical digital inputs applied on IO modules to the position of breakers or similar.

3. "Monitoring" provides a high level overview of the installation as well as detailed information about each individual EXpvX slave.
4. "Control" gives access to set up of ECpvX Cluster controller related parameters such as IP configuration, Internal clock handling etc.
5. "Settings" give access to setup of site specific parameters such as number of ECpvX slaves and ratings of inverters.
6. "Logs" give access to setup of log specific parameters.

In the following chapters the content of the six menu tiles are discussed in detail.

Control

Under this tile set up of ECpvX Cluster controller related parameters for IP configuration, Internal clock handling etc. are found.

IP configuration

First page presented when clicking the Control tile is the below page where IP configuration is set up and connectivity to the gateway can be tested.

ENcombi ADMIN

IP config

IP address: 192.168.1.90

Netmask: 255.255.255.0

Gateway: 192.168.1.1

DNS config

DNS server 01: 8.8.8.8

DNS server 02: 8.8.4.4

IP setup page.
Connectivity to gateway and DNS server can be tested.

Test:

2021-09-12-11:34:40

On the right hand side there are four submenus for.

1. Internal clock.
2. Email client.
3. FTP client.
4. ECpvX Cluster server access.

Internal clock

The internal clock can be synchronized against an NTP server as well as be set manually.

NTP synchronization

First page presented when clicking the clock button is the below page where NTP synchronization can be set up and connectivity to an NTP server and its functionality can be tested.

NTP config

NTP address 1: 193.204.114.232

NTP address 2: 193.204.114.233

UTC: 1

Daylight: EUROPEAN

NTP sync hour: 0:00

NTP: DISABLED



NTP setup page.
Connectivity to an NTP server can be tested.

Test:

188.40.88.13



2021-09-12-11:35:00

On the same submenu level the manual time adjustment of the internal clock is found. Clicking the up/down arrows will lead to it.

Manual time adjustment

On the page below the internal clock can be set manually. The time of the PC connected is presented and can be used to set the ECpVX Cluster clock against.

Manual config

PC time: 2022-09-12-11:35:30



PLC time:



Manual device clock adjustment.
PC time shown for reference.

2021-09-12-11:35:33

Email client

The ECpvX Cluster can send out emails. It can be set up to automatically notify in case of event/alarm occurring as well as sending out the event logs when completed. This is discussed in detail in the Logs chapter later in this document. The customer/installer must make use of their own email account.

Account

First page presented when clicking the mail button is the page below where the email account is set up. Connectivity to the mail server as well as functionality can be tested.

ENcombi ADMIN

Email config

SMTP server: smtp.gmail.com

SMTP port: 465

SMTP SSL: ENABLED

SMTP username: username

SMTP password: *****

Mail service: DISABLED

Receiver address: receiver@gmail.com

SMTP setup page.

SMTP setup relates to the email account from which the device is to send out emails.
 If to send out the email from an account of your own, then type in the associated SMTP details for that account. Alternatively you can use the build in email account. To do this just enable the mail service setting. In this case all the SMTP settings will be disregarded.

A maximum of 30 characters in mail addresses are allowed.

Connectivity to a SMTP server can be tested.
 Test mail can be send to selected receiver address.

Test: smtp.gmail.com

Test: receiver@gmail.com

2021-09-12-11:36:32

On the same submenu level the set up of automatic email transmissions is found. Clicking the up/down arrows will lead to it.

Automatic email transmission

On the page below the automatic transmission of emails is set up.

Auto Email

Event log: DISABLED

Attach log: DISABLED

Attempts: 3



Automatic Email setup page.
 Transmission of mail can be triggered by occurrence of alarms and/or events.
 The latest log entry will be in the mail text.
 The entire event log can be attached as well.
 Number of re-transmission attempts can set.

2021-09-12-11:52:29

FTP client

The ECpvX Cluster has an FTP client and can transfer logs to an FTP server. It can be set up to do so automatically in case of event/alarm occurring as well as transferring the summary and production logs when completed. This is discussed in detail in the Logs chapter later in this document. The customer/installer must make use of their own FTP server.

FTP server

First page presented when clicking the FTP button is the page below where the FTP server details are set up. Connectivity to FTP server as well as functionality can be tested.

FTP config

FTP server: myftpserver.com

FTP path:

FTP client port: 21

FTP passive: ENABLED

FTP username: username

FTP password: *****



FTP setup page.
 Path to sub folder on FTP server can be setup.
 Path must be provided as indicated in below example.
 /Folder/SubFolder/.
 No path entered equals FTP server root directory.
 Connectivity to a FTP server can be tested.
 Transfer of an empty file FTPTest.txt can be tested.

Test:



2020-07-10-13:12:58

On the same submenu level the set up of automatic FTP transfer is found. Clicking the up/down arrows will lead to it.

Automatic FTP transfer

On the page below the automatic transfer of files is set up.

ENcombi ADMIN

Auto FTP		  <div style="border: 1px solid black; padding: 5px; margin-top: 10px;"> <p style="font-size: small;">Automatic FPT file transfer setup page. Transmission of event log file can be triggered by occurrence of alarms and/or events. Number of re-transmission attempts can set.</p> </div> 
Event log:	DISABLED	
Attempts:	3	

2021-09-12-11:52:57

ECpvX Cluster server access

The ECpvX Cluster features three servers:

1. FTP server.
2. Telnet server.
3. Web server (ECweb).

ECpvX FTP server

First page presented when clicking the server button is the page below where the FTP server access details are set up.

Two sets of credentials exist.

1. Credential set0 will provide access to the PLC_PRG folder on the SD-card.
2. Credential set1 will provide access to the Logs folder on the SD-card.

FTP server access in general can furthermore be enabled/disabled.

FTP Server:

User0: ftp_user0

Password0: *****

User1: ftp_user1

Password1: *****

FTP: ENABLED



FTP server setup page.
Credential0 is for remote SW update via FTP.
Credential1 is for reading out logs via FTP.

2020-07-10-13:14:07

On the same submenu level the set up of telnet server access is found. Clicking the up/down arrows will lead to it.

ECpvX Telnet server

On the below page the telnet server access is set up. It is normally not used as it is intended for debug purposes only by tracing various ECpvX Cluster client activities. Telnet server access in general can furthermore be enabled/disabled.

TELNET Server:

User0: telnet_user0

Password0: *****

Telnet: ENABLED



Telnet server setup page.
Credential is for device telnet server access.
Telnet is usable for tracing various device client activities.

2020-07-10-13:14:30

On the same submenu level the set up of web server access is found. Clicking the up/down arrows will lead to it.

ECpvX web server (ECweb)

On the page below the web server access is set up.

The HTTP port can be changed. This can be useful if to access ECpvX Cluster from outside the LAN using port forwarding and multiple ECpvX's or other devices also featuring a web server are connected to the LAN as well.

ENcombi

ADMIN

WEB Server:

User0: web_user0

Password0: *****

HTTP port: 80

WEB server setup page.
Credential is for device WEB server access.
The HTTP port can be changed which can be useful if to setup
port forwarding in a router/gateway to the device.

2020-07-10-13:14:49

Identifiers

Under this tile overview of SW version installed and extras present in the ECpvX Cluster as well as set up of project details (name, location etc.), password scheme etc. are found.

ECpvX information

First page presented when clicking the Identifiers is the below page where various details about the ECpvX Cluster such as extras available, SW version, serial number etc. Also the MAC address can be found.

ENcombi
ADMIN

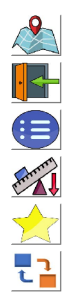
Company:				
Name:	Website:	Contact:	Support:	
ENcombi	www.encombi.com	sales@encombi.com	support@encombi.com	
Product:				
Type:	Extras:	Project version:	Serial number:	
ECpvx	-C-	1.00.0	202205200001	
Platform:				
Device type:	Device variant:	Chip type:	Rtos:	Version:
WP240X	COM	SC24L	V2.07 FULL	V23.9.63.1
Identifiers:				
Serial number 1:	Serial number 2:	MAC address:		
C3DD7428B3FA5D66	0B0FAB82B7B8BA18	026109610B20		

2021-09-12-12:54:39

On the right hand side there are five submenus for.

1. Project details.
2. Password scheme.
3. Extras.
4. Metrics.
5. Backups.
6. Application

Project details

Clicking the location button leads to the below page where project details such as site name and location can be entered. Site name is used for the topic when ECpvX Cluster sends out emails.

Project details:

Site: Holstebrovej 75
 Customer: Sterregaards
 Installer: Claes
 Install date: 2018-03-04



Site details setup page.
 The site name will be used by the device as the
 "from-alias" when sending out Emails.

Location details:

Country: Denmark
 Region: Midtjylland
 City: Viborg
 Latitude: 56.4483
 Longitude: 9.3786

2020-07-10-13:19:03

Password scheme

Clicking the log-in button leads to the below page where the password scheme can be enabled/disabled.

Passw. scheme:

Timeout: 180 s
 Scheme: DISABLED
 ECpanel
 Show passw: DISABLED



Password editing scheme setup page.

The password editing scheme can be enabled/disabled by the administrator.
 Level required for editing other settings, start/stop of plant etc. can be configured on dedicated permission setup pages.
 If password scheme is disabled, all users logged into web server will have administrator rights.
 Default passwords:
 Administrator: Password0.
 Service: Password1.
 Operator: Password2.
 The display of the ECpanel password in clear text on the ECpanel can be enabled.

2021-03-31-08:37:58

The password scheme holds four access levels:

1. Administrator.
2. Service.
3. Operator.
4. Viewer.

Required access levels of the various functionalities can be tailored by the customer as shown later. Whenever an attempt is made to alter/activate anything which is not allowed with the current access level, ECpvX Cluster will discard the command and populate a message text informing which access level is required to apply the command.

Viewer level is obtained just by logging on to ECweb.

When to change the access level the upper right text string informing about the current access level is to be clicked. Doing that leads to the below log-in page.

When logging in the requested access level and associated password is typed in. When the correct password is typed in the padlock will open. Hereafter the log-in button must be clicked. That will give the selected access level and take you back to the previous page.

When logging out just click the log-out button. The ECpvX Cluster will log out automatically when no editing occurs within the timeout period. Users will be degraded to Viewer level and must log in again as described above to regain the required access level.

When the password scheme is disabled as per default the user will have administrator rights.

Only an administrator can disable the password scheme.

Besides the enabling of the password scheme for ECweb itself, there is a setting for enabling visualization of the ECpanel password in clear text on the ECpanel itself. When disabled the ECpanel password is hidden on the ECpanel.

On the same submenu level the set up pages for Operator, Service and Administrator level passwords are found. Clicking the up/down arrows will lead to them.

Passwords

Operator access or high is required for changing the Operator password.

Service access or high is required for changing the Service password.

Administrator access is required for changing the Administrator password.

three dedicated menus exist for changing the passwords. Below example for changing Operator password.

ENcombi

Operator

ADMIN

Password:

Operator password setup page.
At least operator level login required
for changing operator password.

2020-07-10-13:23:09

On the same submenu level the set up pages for tailoring access level required for executing various commands are found. Clicking the up/down arrows will lead to them.

Permissions

The various access levels required are set as below example.

ENcombi

ADMIN

Log

Log setup:	SERVICE
Log deletes:	SERVICE
Settings	
Settings:	SERVICE
Counters:	SERVICE
EClogic	ADMIN

Permissions setup page.
Setup password level required
for various actions.
Admin level login required for that.

2021-09-12-13:17:22

Only an administrator can change the access level required for the various functionalities.

License & Extras

Clicking the extras button leads to the page below where activation of License can be done from here.

ENcombi

ADMIN

Extras:

Search online: 

Search on USB: 

License page.
 Contact dealer for purchase of license.
 When purchased, the license can be fetched
 by the device either online or from a USB stick.
 If online, the device must have access to the internet.
 If from USB stick, goto www.encombi.online to download license.

2021-09-12-13:18:22

After purchase of License the ECpvX Cluster is upgraded in one of the following ways.

Search online

The ECpvX Cluster will have to be connected to the internet for this approach. Click the binoculars button for "Search online". When successfully completed the ECpvX Cluster will request a reboot.

Search on USB

The License for the specific ECpvX Cluster are to be downloaded from ECcloud on www.encombi.online and put on the root directory on a USB stick. Insert the USB stick in the USB port on the ECpvX Cluster and click the binoculars button for "Search on USB". The ECpvX Cluster will check the USB stick for the upgrade. When successfully completed the ECpvX Cluster will request a reboot.

Metrics

Clicking the metrics button leads to the below page where the metrics to use by ECpvX Cluster can be set up. The ECpvX Cluster will use the selected metrics for various displays on ECweb as well as in ECcloud.

Settings

Currency: Euro

Volume: liter

Mass: kg



Metrics setup page.
Selected units will be used for
various associated counters and derivatives.

Backups

Clicking the Backup button leads to the below page where the backups supported by ECpvX Cluster are managed. The ECpvX Cluster provides two backups.

1. Settings.
2. Counters.

Both types can be:

1. Generated and stored locally on internal memory of ECpvX Cluster.
2. Loaded into ECpvX Cluster project from internal memory of ECpvX.
3. Copied from internal memory of ECpvX Cluster to ENcombi cloud for save storage.
4. Read from ENcombi cloud to internal memory of ECpvX Cluster.
5. Generated and stored on USB-stick.
6. Loaded into ECpvX Cluster project from USB-stick.

When reading backups from the cloud it will overwrite any existing backup already present on the internal memory of the ECpvX Cluster. The presents of and date of origin of the backups on internal memory are displayed.

Per default when reading backups from ENcombi cloud, the ECpvX Cluster will read backups generated by itself. If to clone an ECpvX Cluster this can be done by typing in the MAC access of the ECpvX Cluster you request to clone. Doing this ECpvX Cluster will read backups generated by that ECpvX Cluster instead.

ADMIN

Backup	Date	Action
Settings	2020-06-06-10:41:45	
Counters	N.A.	
MAC address:	0030569108A2	

Device backup page.
Following backups can be made:

- 1: Settings backup.
- 2: Counter backup.

The backups are saved and loaded locally on/from the device.
One backup for each function exist only.
Saving a new backup will overwrite any existing backup.

Backups can also be saved and read in/from cloud service.
One backup for each function per device can be saved only.
Reading a backup from cloud service,
will overwrite any existing local backup.

Furthermore backups can be saved on and loaded
from USB memory stick.

To clone a device, backups created from other devices
can be read from the cloud and loaded.
To do so, the MAC address of the device to clone from
must be typed in. The refresh button resets to the
MAC address of the device itself.

2020-07-10-13:25:29

Application

Clicking the Application button leads to the page below. Here it can be selected which application is to be active.

ENcombi

ADMIN

Application

Application: ECPVX

Application swap page.
Here it is set up which application to run.
When toggling between applications, the device is to be rebooted. Any settings made in the ECpvx application will be lost in the process. Store a backup before leaving the ECpvx project if any settings are made that is to be restored when reverting to the ECpvx application. Browser needs refreshing when the device has rebooted.

2021-08-18-11:50:05

The following applications are available.

1. ECpvX Cluster.
2. ECpvX Cluster Service Tool.
3. ECpvX Cluster Boot

ECpvX Cluster is the default application and the one to use for the normal operation of the ECpvX Cluster. ECpvX Cluster Service Tool is a separate application that offers various tests and configuration features and the ECpvX Cluster Boot is a tool for updating both the ECpvX Cluster and the ECpvX Cluster Service Tool SW. The ECpvX Cluster Service Tool and the ECpvX Cluster Boot are treated in separate chapters.

When toggling between applications the device is to be rebooted. Any settings made in the ECpvX Cluster application will be lost in the process. Make a backup before leaving the ECpvX Cluster application if any settings are made that are to be restored when reverting to the ECpvX Cluster application once again. The browser needs refreshing when the device is rebooted after switching the application.

Settings

Under this tile the setup of site specific parameters as numbers and ratings of ECpvX slave can be found.

RS485 COM ports

The ECpvX Cluster features two RS485 COM ports which are referred to as COM2 and COM3.

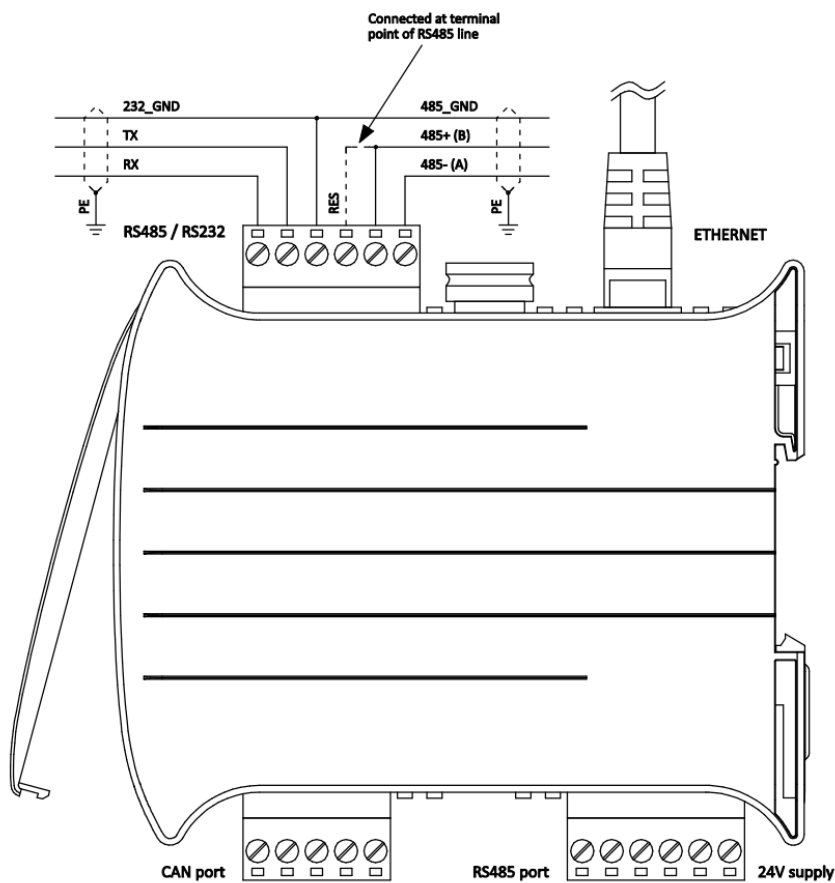

COM2 is the one found next to the power supply and COM3 is the one found next to the ethernet port.

- COM2 is reserved for interfacing to power meters and/or meteorological sensors.
In case none of this is enabled, COM2 is acting as a slave port.
- COM3 is reserved for interfacing to ECpvX slaves and/or meteorological sensors.
In case none of this is enabled, COM3 is acting as a slave port.

First page presented when clicking the Settings tile is the below page where COM2 configuration is set up.

COM2 port

Baudrate:	19200
Parity:	NO PARITY 1 STOP BIT
Timeout:	0.3 s
TX rate:	1.0 s
Slave ID:	1



COM2 Port setup page.
Baudrates supported are 9600, 19200, 38400 and 115200.
Power meter RTU communication is fixed on COM2.
Sensor and IO module RTU communication is optional on COM2.
In case none of these communications are enabled, COM2 is serving as a Modbus RTU slave.
Slave ID is only used in case COM2 is serving as a slave.



2021-09-12-13:55:56

Baud rates supported are:

- 9600, 19200, 38400 and 115200

Parity supported are:

- "Parity one stop bit", "No parity", "Even parity" and "Odd parity".

When a COM2 port is acting as a master, the transmit rate can be used to control the rate at which the ECpvX Cluster transmits to the slaves.

The Slave ID is only used when a COM2 port is acting as a slave.

On the same menu level a similar setup page for COM3 configuration is found. Clicking the up/down arrows will lead to it.

On the right hand side there are four submenus for.

1. Battery related parameters.
2. IO module related parameters.
3. Alarm related parameters.
4. Modbus slave profiles.

Battery

Measurement

Clicking the battery button leads to the below page where the measurements can be set up.

ENcombi ADMIN

Measurement

kW Origin: INVERTER ACQ.

kWh Origin: ECPVX

Battery reference setup page.
 Priority setting determines whether to prioritise P or Q reference over the other in case exceeding rated S inverter capacity.

Max dispatch limits can be set for parallel operation to both grid and gensets respectively. In case the reference is exceeding, the device will limit the P reference.

Cosphi cap and Cosphi ind outlines operating range of the inverters. In case enabled and reference exceeding, the device will limit the Q reference.

Sensing method determines if to base reference on the sum of all phases or 3 x sensing values.

kW origin determines from which source the battery power production arises.

kWh origin determines from which source the battery energy production arises.

2021-09-12-14:12:00

kW origin determines from where to retrieve/calculate the Battery power production. Supported methods are:

1. Inverter acquisition.

Inverter acquisition

The ECpvX Cluster will take the power contribution of the individual ECpvX slaves directly from their own power measurements via the inverter communication.

kWh origin determines from where to retrieve/calculate the PV energy production. Supported methods are:

1. ECpvX Cluster.
2. EcpvX slaves

ECpvX

Based on the kW measured, the ECpvX Cluster integrates energy counters itself.





ECpvX slaves

The ECpvX Cluster will read the total energy counter from each ECpvX slave and base the energy from the reading.

SOC Balancing

On the same submenu level the menu for setting up the SOC balancing is found. Clicking the up/down arrows will lead to it.

ENcombi ADMIN

SOC Bal. Charge				<p>SOC balancing setup page. SOC balancing works in grid and genset parallel operation only. The SOC balancing in a charging condition is triggered when one or more batteries have a SOC deviation that exceeds the set threshold value from the battery with the highest SOC. The SOC balancing in a discharging condition is triggered when one or more batteries have a SOC deviation that exceeds the set threshold value from the battery with the lowest SOC. When balancing is ongoing the respective batteries will share the power reference among them. Any remaining reference that can not be accommodated by the balancing batteries will be shared among the rest.</p>		
SOC high thr:	5.0					
SOC low thr:	2.0					
SOC balancing:	ENABLED					
SOC Bal. Discharge						
SOC high thr:	5.0					
SOC low thr:	2.0					
SOC balancing:	ENABLED					

2022-02-13-19:50:17

SOC balancing works in grid and genset parallel operation only; that is the mode received from the ECpvX Master must be PQ mode. The SOC balancing in a charging condition is triggered when one or more batteries have a SOC deviation that exceeds the set threshold value from the battery with the highest SOC. The SOC balancing in a discharging condition is triggered when one or more batteries have a SOC deviation that exceeds the set threshold value from the battery with the lowest SOC. When balancing is ongoing the respective batteries will share the power reference among them. Any remaining reference that can not be accommodated by the balancing batteries will be shared among the rest.

DOD thresholds

On the same submenu level the menu for setting up the DOD counter thresholds is found. Clicking the up/down arrows will lead to it.

The DOD counter is incremented when the SOC drops below the low threshold and once again reaches the high threshold.

Counters

On the same submenu level pages for various battery related counters are found. Clicking the up/down arrows will lead to them.

- Produced energy (daily, monthly, yearly and total).
- DOD counters (daily, monthly, yearly and total).

Below is an example.

The counters will be incremented automatically by the ECpvX Cluster in accordance with operation conditions. The counters are part of the counters backup discussed in the Identifier chapter.

The menus are only providing the possibility for manually presetting of the counters. Counters with a check mark in the update column will be preset with the keyed in value when the save button is pressed. Toggle between check mark and cross mark by pressing the respective buttons.

Inverter

Clicking the inverter button leads to the following page.

The screenshot shows the ENcombi web interface. At the top left is the ENcombi logo, and at the top right is the word 'ADMIN'. Below the logo is the title 'Inverter'. A table lists the following settings:

Protocol:	OFF
Modbus type:	RTU
Control Fnc:	0x10
Control:	DISABLED
Data acquisition:	DISABLED
Number:	1

In the center of the page, there is a box with a pencil icon and up/down arrows. The text inside the box reads:

Battery inverter setup page.
 The device can interface to a battery inverter via Modbus RTU or Modbus TCP.
 Besides controlling the inverter, the device can also do data acquisition. If data acquisition enabled, the device will read production data from the inverter.
 The data read, will be visualized on dedicated page.

On the right side, there is a navigation menu with an 'Inverter settings' button.

At the bottom right of the page, the timestamp '2021-09-12-14:30:54' is displayed.

A maximum of 32 ECpvX slaves is supported by a single ECpvX Cluster. In case more than 32 ECpvX slaves are to be controlled, multiple ECpvX cluster can be stacked to work together. The communication can be either Modbus RTU or TCP.

Controlling the slaves and data acquisition from the slaves can be enabled/disabled independently. ECpvX cluster supports Modbus function code 0x06 and 0x10 for applying control commands.

If data acquisition is enabled, the data read from the slaves, will be visualized on dedicated pages under monitoring.

RTU

On the same submenu level the page for setting up Modbus RTU specifics for slave communication is found. Clicking the up/down arrows will lead to it.

RTU

Control type: UNICAST

Control ID: 1

Acquisition ID: 1



Inverter interface via Modbus RTU setup page.
Here the Modbus ID of the battery inverter is set.



2021-09-12-14:33:07

The ECpvX cluster can communicate with the slaves on RTU. It will use unicast and the control ID and acquisition ID must be the same in order to communicate with the slaves.

TCP

On the same submenu level the page for setting up Modbus TCP specifics for slave communication is found. Clicking the up/down arrows will lead to it.

TCP

Control IP: 192.168.1.50

Acquisition IP: 192.168.1.50

TCP-RTU converter: DISABLED



Inverter interface via Modbus TCP setup page.

When controlling a pool of inverters, without the presents of a managing controller, the Control IP is to be set differently than the Acquisition IP. The RTU Initialization ID is in this case used for any initialization frames. The RTU Control ID is in this case used for all other frames. The IP addresses of the inverters must be sequential.

When controlling a single inverter or a pool of inverters with the presents of a managing controller, the Control IP is to be set equal to the Acquisition IP. The RTU Initialization ID is used for any initialization frames. The RTU Control ID is used for the control frames. The RTU Acquisition IDs are used for the data acquisition frames.

When controlling a single inverter or a pool of inverters via TCP-RTU converter, the Control IP is to be set equal to the Acquisition IP. The RTU Initialization ID is used for any initialization frames. The RTU Control IDs are used for the control frames. The RTU Acquisition IDs are used for the data acquisition frames.



2020-07-10-13:40:48

When controlling a pool of ECpvX slaves the Control IP is to be set differently than the Acquisition IP.

- The RTU ControllID is used for TCP frames for both acquisition and control references. The IP addresses of the inverters must be sequential.

When controlling a single ECpvX slave, the Control IP is to be set equal to the Acquisition IP.

- The RTU Control ID is used for the TCP frames related to control references.

- The RTU Acquisition IDs are used for the TCP frames related to data acquisition.

Advanced Inverter command setup

On any of the above inverter pages clicking the Command button will lead to the below page for advanced inverter command setup.

ENcombi ADMIN

Inverter Cmd

Interval:	300.0 s
P timeout:	60 s
Q timeout:	60 s

Common inverter command setup page.
 The delay between transmission of commands
 that is set to be transmitted at defined interval
 and reference fallback timeout values can be set here.
 Protocol specific command configuration
 is found on the following pages.

2020-07-10-13:41:08

These settings are common for all inverters and may or may not apply to the specific inverter make/model selected. Here the delay between transmission of commands that is set to be transmitted at a defined interval can be set. Furthermore the fallback timeouts for reverting to a predefined production level in case of loss of communication can be set up.

Battery ratings

Clicking the battery button leads to the following page.

ENcombi ADMIN

Rated	0
Inverter S:	20.0 kVA
Inverter Q:	20.0 kVA
Battery P:	20.0 kW
Hour:	1.0 hour

Battery capacity setup page.
 S and Q refers to installed inverter capacity.
 P and hours refers to installed battery capacity.

2021-09-13-11:15:47

From here it is possible to setup the size of each ECpvX slave. It is possible to setup 32 slaves by toggling the arrow buttons up and down.

DOD settings

On the same submenu level the setup page for DOD settings is found. Clicking the up/down arrows will lead to it.

ENcombi

ADMIN

DOD settings

DOD high thr: 90.0

DOD low thr: 50.0



DOD threshold setup page.
 DOD threshold can be setup with a high and low threshold.
 When a full SOC cycle is made based on the threshold, the DOD counter will increase



2022-03-14-11:15:32

DOD threshold can be set up in order to count a DOD cycle. When a full cycle is made based on the threshold, the DOD counter will increase.



IO modules

Clicking the IO module button leads to the following page.

ENcombi VIEWER

IO modules

COM port:	COM2
IO 1:	OFF
IO 2:	OFF
IO 3:	OFF
IO 4:	OFF

IO module setup page.
 IO module communication can either run Modbus RTU or Modbus TCP.
 Whether to use COM2, COM3 or TCP is selectable by parameter.
 Port settings is setup at dedicated port setup page.



2021-01-22-17:11:09

Above page holds the setting up Modbus IO module communication. IO module communication runs either Modbus RTU or Modbus TCP. Whether to use IO modules on COM2, COM3 or TCP is selectable by parameter. A maximum of 4 Modbus IO modules can be connected to the ECpvX Cluster. The ECpvX Cluster can also read IO data directly from another ECpvX. This is selectable by parameter.



Check the link below to see which IO modules that are supported by ECpvX Cluster.
<http://www.encombi.com/products/ecpvx/>

Clicking the up/down arrows leads to the page below where the Modbus ID and IP addresses for the respective IO modules are set up.

ENcombi ADMIN

IO modules

IO 1 ID:	1
IO 1 IP:	192.168.1.50
IO 2 ID:	1
IO 2 IP:	192.168.1.50
IO 3 ID:	1
IO 3 IP:	192.168.1.50
IO 4 ID:	1
IO 4 IP:	192.168.1.50

IO module setup page.
 Modbus RTU ID of the IO modules is selectable by parameter.
 Modbus TCP IP of the IO modules is selectable by parameter.
 The Modbus ID selected is used in the TCP frames.



2021-01-24-11:56:05

Analogue input/output

The ECpvX Cluster supports analogue input/output modules. When the analogue module is selected in the IO window setup, all settings are placed in the monitoring of the IO module.

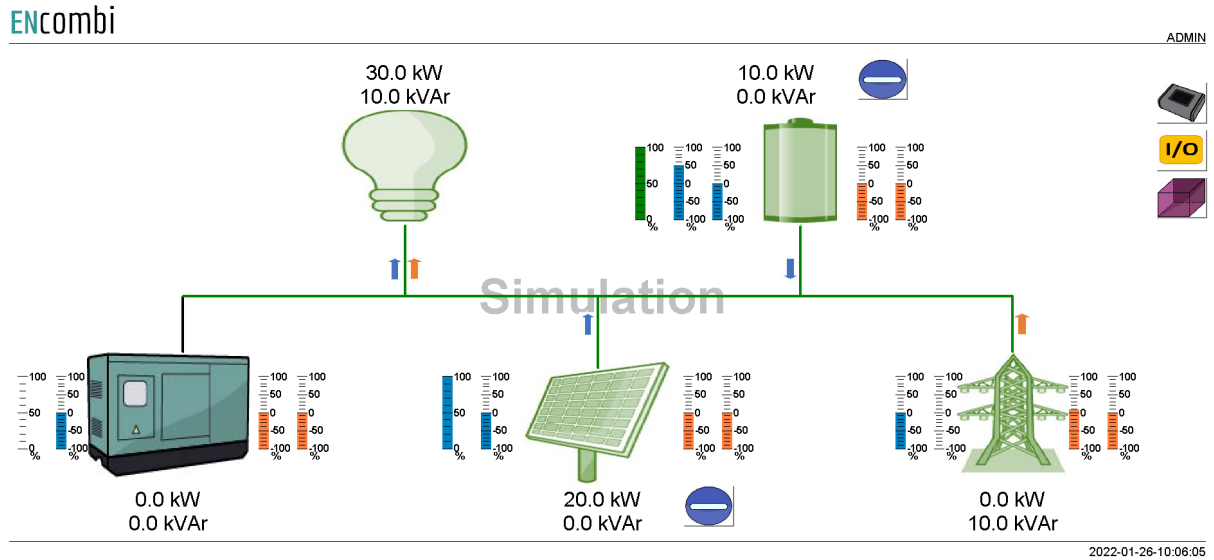



When pressing the IO button, it will lead to the following page.

The screenshot shows the 'IO modules' configuration page. It features a table with columns for IO modules, IO type, IO inputs, IO outputs, and communication state. There are also thumbs-up icons and communication enable buttons for each module.

IO modules	IO type	IO inputs	IO outputs	Communication state:	Communication enable:
IO 1:	EX04AIO	N.A	N.A		<input type="checkbox"/> Communication enable:
IO 2:	EX04AIO	N.A	N.A		<input type="checkbox"/> Communication enable:
IO 3:	EX1608DD	0011 0000 0000 1100	0000 0000 0000 0000		<input type="checkbox"/> Communication enable:
IO 4:	EX04AIS	N.A	N.A		<input type="checkbox"/> Communication enable:

The date '2022-02-01-09:20:08' is visible at the bottom right.

From this page it is possible to select which IO module to set up and monitor values. If the IO module is digital input/output, it is not possible to click on the module, the actual bit value is present at this page. By clicking on the IOx module, it will lead to the following page.

IO2	AIO type	Value	PCT	Minimum Scale	Maximum Scale	State:
Channel 1:	INPUT	1500.0	36.6 %	0.0	4095.0	Normal 
Channel 2:	INPUT	2000.0	48.8 %	0.0	4095.0	Normal 
Channel 3:	OUTPUT	0.0	0.0 %	0.0	4095.0	Normal
Channel 4:	OFF	N.A	N.A	0.0	4095.0	N.A

Module temp: 32.2 C

Communication state: 

2022-02-07-14:16:54

From this page it is possible to scale the input/output on each channel of the IO module. The input value can be used for Pref, Qref or other data points. This is set in EClogic. The value shown is the scaled value and the percentage is the percentage of the range from 0-100%. The maximum range is 0-4095. The module temperature is shown in the lower right corner and the state of each channel can be read to the right.

Alarms

Clicking the alarm button leads to menus of customizable alarms.

- COM2 port slave alarm.
- COM3 port slave alarm.
- TCP port slave alarm.
- Common master communication alarm.

Other alarms exist as well but they are not customizable alarms as the ones listed above.

COM2 slave

ENcombi

ADMIN

COM2 slave

Delay:	5.0 s
Enable:	DISABLED
Signal:	DISABLED
Action:	NOTIFICATION
Auto ack.:	DISABLED



COM2 slave alarm setup page.
 When no frames are received from modbus master the alarm condition is present.
 When condition has been present for a periode equal to or longer than the delay and in case the alarm is enabled, the alarm is provoked.
 When alarm is provoked, the signal selected will be activated and the action selected will be taken.
 The alarm is automatically acknowledged in case auto ack. is enabled.



2020-07-10-13:50:04

When no frames are received from the modbus RTU master, the alarm condition is present. When the condition has been present for a period equal to or longer than the delay and in case the alarm is enabled, the alarm is provoked. When the alarm is provoked, the signal selected will be activated and the action selected will be taken. The alarm is automatically acknowledged in case auto ack. is enabled.

COM3 slave

ENcombi

ADMIN

COM3 slave

Delay:	5.0 s
Enable:	DISABLED
Signal:	DISABLED
Action:	NOTIFICATION
Auto ack.:	DISABLED



COM3 slave alarm setup page.
 When no frames are received from modbus master the alarm condition is present.
 When condition has been present for a periode equal to or longer than the delay and in case the alarm is enabled, the alarm is provoked.
 When alarm is provoked, the signal selected will be activated and the action selected will be taken.
 The alarm is automatically acknowledged in case auto ack. is enabled.



2020-07-10-13:50:21

When no frames are received from the modbus RTU master, the alarm condition is present. When the condition has been present for a period equal to or longer than the delay and in case the alarm is enabled, the alarm is provoked. When the alarm is provoked, the signal selected will be activated and the action selected will be taken. The alarm is automatically acknowledged in case auto ack. is enabled.

TCP slave

TCP slave

Delay:	5.0 s
Enable:	DISABLED
Signal:	DISABLED
Action:	NOTIFICATION
Auto ack.:	DISABLED



TCP slave alarm setup page.
 When no frames are received from modbus master the alarm condition is present.
 When condition has been present for a periode equal to or longer than the delay and in case the alarm is enabled, the alarm is provoked.
 When alarm is provoked, the signal selected will be activated and the action selected will be taken.
 The alarm is automatically acknowledged in case auto ack. is enabled.

2020-07-10-13:50:43

When no frames are received from the modbus TCP master, the alarm condition is present. When the condition has been present for a period equal to or longer than the delay and in case the alarm is enabled, the alarm is provoked. When the alarm is provoked, the signal selected will be activated and the action selected will be taken. The alarm is automatically acknowledged in case auto ack. is enabled.

Common master communication

Comm alarm

Delay:	60.0 s
Enable:	ENABLED
Signal:	DISABLED
Action:	NOTIFICATION
Auto ack.:	ENABLED



Common modbus master communication alarm setup page.
 When any modbus master communication alarm is triggered, then the alarm condition is present.
 When the condition has been present for a periode equal to or longer than the delay, and in case the alarm is enabled, the alarm is provoked.
 When the alarm is provoked, the signal selected will be activated and the action selected will be taken.
 The alarm is automatically acknowledged in case auto ack. is enabled.

2022-03-10-10:13:08

This alarm condition is present in case any of the modbus master communication alarms for the inverter, power meter, sensor or IO communication are raised. When the condition has been present for a period equal to or longer than the delay and in case the alarm is enabled, the alarm is provoked. When the alarm is provoked, the signal selected will be activated and the action selected will be taken. The alarm is automatically acknowledged in case auto ack. is enabled.

Proprietary modbus pages

Clicking the pages button leads to the following page.

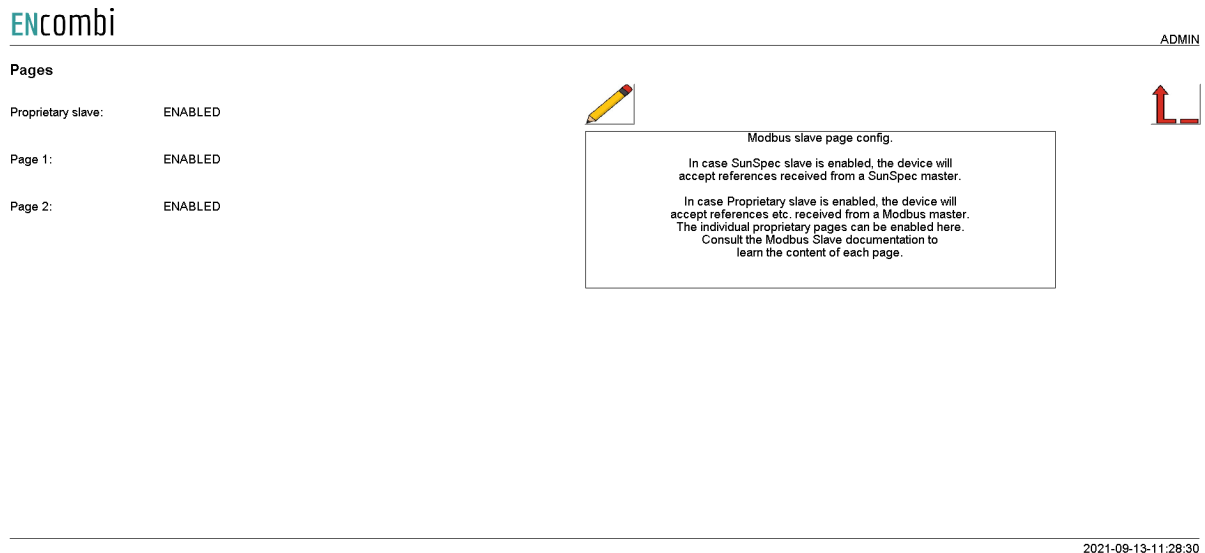

ENcombi ADMIN

Pages

Proprietary slave:	ENABLED
Page 1:	ENABLED
Page 2:	ENABLED

Modbus slave page config.

In case SunSpec slave is enabled, the device will accept references received from a SunSpec master.

In case Proprietary slave is enabled, the device will accept references etc. received from a Modbus master. The individual proprietary pages can be enabled here. Consult the Modbus Slave documentation to learn the content of each page.

2021-09-13-11:28:30

In case Proprietary slave is enabled, the ECpvX cluster will accept instructions to be received over modbus via a dedicated proprietary modbus profile. The various instructions are furthermore grouped together in different pages that need to be enabled individually.

Consult the Modbus slave documentation on ENcombi website for detailed information about the proprietary modbus profile.

<http://www.encombi.com/products/ECpvx/>

Logs

The ECpvX Cluster offers logging both locally on SD-card or USB-stick and as time series data pushed to an online database.

Local logs with transmission via mail/ftp

The ECpvX Cluster features logging stored locally on SD-card or on USB stick. The ECpvX Cluster can make event logs:

The logs are stored locally on ECpvX Cluster; either on SD-card or on USB-stick.



ENcombi ADMIN

Log config

Log drive:	SD-card
Event log:	DISABLED
Log rate:	5 min



Log setup page.
 USB-key or SD-card can be used for logging.
 Use of USB-key recommended to avoid wearing SD-card.
 Three logs can be enabled/disabled independently.
 Event-log holds events and alarms.
 Summary-log holds the result of a days production.
 Production-log holds fixed interval loggings
 of production during a day.
 The logs can be read directly on web server
 as well as be transmitted via ftp or mail.
 Selected storage media must hold a "Logs" folder in the root directory.

Event log:  

2021-09-13-11:32:08

A new Event log is generated every day. The event log holds entries of any events taking place or any occurrences of alarms on that particular day. All entries are time stamped. The ECpvX Cluster can be set up to notify by email when a new entry is made in the event log. The ECpvX Cluster will in the text include the six most recent entries in the log.

The log can be displayed directly on ECweb. Below is an example of the eventlog and how it looks on ECweb.

The screenshot shows the ENcombi web interface. At the top left is the ENcombi logo. On the right, it says 'ADMIN'. Below the logo is a navigation bar with several icons: a blue 'K', a yellow double arrow pointing left, a blue arrow pointing left, a white box containing '42..80 \ 80', a blue arrow pointing right, a yellow double arrow pointing right, and a blue arrow pointing right. To the right of these icons is a blue circle with a white 'X'. Below this is a scrollable list of dates arranged in three columns. The first column contains dates from 2020-05-11 to 2020-06-05. The second column contains dates from 2020-06-06 to 2020-06-18. The third column contains dates from 2020-06-19 to 2020-07-10. At the bottom right of the interface, the timestamp '2020-07-10-13:54:17' is displayed.

The screenshot shows the ENcombi web interface. At the top left is the ENcombi logo. On the right, it says 'ADMIN'. Below the logo is a navigation bar with several icons: a blue 'K', a yellow double arrow pointing left, a blue arrow pointing left, a white box containing '224..239 \ 239', a blue arrow pointing right, a yellow double arrow pointing right, and a blue arrow pointing right. To the right of these icons is a blue circle with a white 'X'. Below this is a scrollable list of event log entries. Each entry consists of a timestamp followed by the text 'Alarm acknowledged'. The timestamps range from 11:35:12 to 11:35:16. To the right of the navigation bar, there is an 'Event log:' label, a white box containing '2021-09-13', and two icons: an envelope icon and a red square icon with a white arrow. At the bottom right of the interface, the timestamp '2021-09-13-11:35:26' is displayed.

Consult the “Control” chapter in this document for details on how to set up the various automatic file transmissions.

EClogic

EClogic provides the possibility of making project specific logical expressions when required. That could be for linking physical digital inputs applied on power meters to the position of circuit breakers or similar. Also here, RRRCR can be set up providing the option of a superior control system to give power references for the ECpv to follow. First page presented when clicking the EClogic tile is the page below.

ELogic main page.

ELogic is a collection of logical features to use for site customization.

The Builder offers the possibility of logically combining various input states.
This is done via graphical representation of logical gates.

Say multiple breakers/contactors need to be in certain position before the PV plant is connected to Grid, this can be tailored in the Builder.

The input to the gates are Modbus addresses and bitmasks.
It will typically be addresses holding digital input statuses from various power meters.
Consult the Modbus Slave documentation to identify the addresses of the inputs to use.
Note that the default input address "0" is interpreted as "not used".

The output of the gates are status set on dedicated Modbus addresses.
Consult the Modbus Slave documentation to identify the addresses of the outputs generated.
These statuses can then be used in the Linker to generate a command to the device.

The Linker offers the possibility of linking input states to commands.
The input states are Modbus addresses and bitmasks.
It will typically be addresses holding digital input statuses from various power meters
or it can be addresses holding output status generated through the Builder.
Consult the Modbus Slave documentation to identify the addresses of the inputs to use.
Note that the default input address "0" is interpreted as "not used".

The commands available are predefined commands on dedicated Modbus addresses.
Consult the Modbus Slave documentation to identify the addresses of the available commands.

The RRCR is a dedicated configuration setup of RRCR functionality.
16 unique Power reference levels based on 4 input combinations can be configured.



2021-09-13-12:17:00

ELogic is divided into five sub categories.

1. Builder
2. Linker
3. IO
4. Command timers
5. Command panel

Builder

The Builder offers the possibility of logically combining various input states. This is done via graphical representation of logical gates.

The input to the gates are function code 0x04 Modbus addresses and bitmasks. It will typically be addresses holding digital input statuses from various power meters. Consult the Modbus Slave documentation to identify the addresses of the inputs to use. Note that the default input address "0" is interpreted as "not used".

The output/status of the gates are set on dedicated Modbus addresses. Consult the Modbus Slave documentation to identify the addresses of the outputs generated. These statuses can then be used in the Linker to generate a command to the device.

First page presented when clicking the builder button is the page below. Here an overview of the 16 builder lines supported is presented.

Each builder line consists of four gates. The status of the gates are represented by the color. Red means that the gate is false and green that the gate is true.

Clicking the line number will lead to the set up page for the specific line.

Each of the first three gates take four AND inputs and four AND NOT inputs. These three inputs are OR'ed together to generate one input to the output gate.

Example (Ecpv example)

In the configuration shown above, address 3397 bit0 is used as input to Gate1. From Modbus Slave documentation this is found to be input1 on PV meter1. As the input1 is active the Gate1 state is true which again results in the output gate to be true. This will generate the following statuses in the designated modbus area to go high.

ECLOGIC BUILDER AREA 1				
28000	Q1 gate output status line 1-16	16 unsigned int	bitwise	Not defined
28001	Q2 gate output status line 1-16	16 unsigned int	bitwise	Not defined
28002	Q3 gate output status line 1-16	16 unsigned int	bitwise	Not defined
28003	Q-out gate output status line 1-16	16 unsigned int	bitwise	Not defined
28004	Inverted Q-out gate output status line	16 unsigned int	bitwise	Not defined
28005...28999	RESERVED	Not defined	Reserved for later use	Not defined

Address 28000 bit0: Gate1, line1
 Address 28003 bit0: Output Gate, line1

Linker

The Linker offers the possibility of linking input states to commands. The input states are Modbus addresses and bitmasks. It will typically be addresses holding digital input statuses from various power meters or it can be addresses holding output status generated through the Builder. Consult the Modbus Slave documentation to identify the addresses of the inputs to use. Note that the default input address "0" is interpreted as "not used".

The commands available are predefined commands on dedicated Modbus addresses. Consult the Modbus Slave documentation to identify the addresses of the available commands.

First page presented when clicking the linker button is the page below. Here the 32 linker lines supported can be set up. Furthermore, the status of each link is indicated by green and red color.

ADMIN

INPUTS				OUTPUTS				INPUTS				OUTPUTS			
Line	Address	Bit	Status	Address	Bit	Status	Line	Address	Bit	Status	Address	Bit	Status		
Line:1	28003	0	■	29019	0	■	Line:17	0	0	■	29000	0	■		
Line:2	28003	0	■	29053	7	■	Line:18	0	0	■	29000	0	■		
Line:3	28003	0	■	29055	2	■	Line:19	0	0	■	29000	0	■		
Line:4	0	0	■	29000	0	■	Line:20	0	0	■	29000	0	■		
Line:5	0	0	■	29000	0	■	Line:21	0	0	■	29000	0	■		
Line:6	0	0	■	29000	0	■	Line:22	0	0	■	29000	0	■		
Line:7	0	0	■	29000	0	■	Line:23	0	0	■	29000	0	■		
Line:8	0	0	■	29000	0	■	Line:24	0	0	■	29000	0	■		
Line:9	0	0	■	29000	0	■	Line:25	0	0	■	29000	0	■		
Line:10	0	0	■	29000	0	■	Line:26	0	0	■	29000	0	■		
Line:11	0	0	■	29000	0	■	Line:27	0	0	■	29000	0	■		
Line:12	0	0	■	29000	0	■	Line:28	0	0	■	29000	0	■		
Line:13	0	0	■	29000	0	■	Line:29	0	0	■	29000	0	■		
Line:14	0	0	■	29000	0	■	Line:30	0	0	■	29000	0	■		
Line:15	0	0	■	29000	0	■	Line:31	0	0	■	29000	0	■		
Line:16	0	0	■	29000	0	■	Line:32	0	0	■	29000	0	■		

2020-07-10-14:01:41

Example continued (Ecpv example)

In the configuration shown above address 28003 bit0 being the status of the output gate of builder line1 is used to set commands on address 29019 bit0, 29053 bit7 and 29055 bit2 respectively. From Modbus Slave documentation this is found to be the commands for:

1. Relay 1-16 on all PV meters.
2. Minimum genset load 1-8.
3. RRCR input 1-4.

Hence activating input1 on PV meter1 has the effect of:

1. Activating relay1 on all PV meters present.
2. Overruling the parameter set under "Settings", using the Minimum genset load setting8 from EClogic instead.
3. RRCR input3 applied.

Point 2 and 3 will be explained in the following.

General Purpose Hysteresis

General purpose hysteresis is a generic configuration tool to trigger alarms based on different inputs.



Address:	Data type:	Data sign:	Low Threshold:	High Threshold:	Low Timer:	High Timer:	Output:	Set:	Reset:	Invert:
0	16BIT	SIGNED	0.0	0.0	0.0 s	0.0 s	■	⊖	⊖	⊙
0	16BIT	SIGNED	0.0	0.0	0.0 s	0.0 s	■	⊖	⊖	⊙
0	16BIT	SIGNED	0.0	0.0	0.0 s	0.0 s	■	⊖	⊖	⊙
0	16BIT	SIGNED	0.0	0.0	0.0 s	0.0 s	■	⊖	⊖	⊙
0	16BIT	SIGNED	0.0	0.0	0.0 s	0.0 s	■	⊖	⊖	⊙
0	16BIT	SIGNED	0.0	0.0	0.0 s	0.0 s	■	⊖	⊖	⊙
0	16BIT	SIGNED	0.0	0.0	0.0 s	0.0 s	■	⊖	⊖	⊙
0	16BIT	SIGNED	0.0	0.0	0.0 s	0.0 s	■	⊖	⊖	⊙

The address column is the input for the flip flop. The data type and sign for the selected address must be changed according to the modbus manual for the address.

The flip flop is built up with a low threshold and a high threshold.

If the value from the address is lower than the low threshold value, the low timer will start. After the lower timer has expired, the output box will change color to green which indicates that the line is present. The status of each line can also be read out on modbus.



If the value from the address is higher than the high threshold value, the high timer will start. After the high timer expires, the output box will change color to red which indicates that the line is not present any more.

It is possible to manually force the line to be set or reset by clicking on the buttons corresponding to the line which should be forced.

Furthermore it is possible to inverse the output by clicking the button.

IO

By clicking on the IO icon, it will lead to the following page.

ENcombi ADMIN  



Address:	Data type:	Data sign:	Module.Channel	Address:	Data type:	Data sign:	Module.Channel
0	16BIT	SIGNED	→ 1.1	0	16BIT	SIGNED	→ 3.1
0	16BIT	SIGNED	→ 1.2	0	16BIT	SIGNED	→ 3.2
0	16BIT	SIGNED	→ 1.3	0	16BIT	SIGNED	→ 3.3
0	16BIT	SIGNED	→ 1.4	0	16BIT	SIGNED	→ 3.4
0	16BIT	SIGNED	→ 2.1	0	16BIT	SIGNED	→ 4.1
0	16BIT	SIGNED	→ 2.2	0	16BIT	SIGNED	→ 4.2
0	16BIT	SIGNED	→ 2.3	0	16BIT	SIGNED	→ 4.3
0	16BIT	SIGNED	→ 2.4	0	16BIT	SIGNED	→ 4.4

2022-02-01-11:08:38

From here it is possible to set up which data should be linked to each output of the AIO module. All 16 outputs are present and it is possible to select which data to be sent out on each channel.



Command timers

By clicking on the command timer icon, it will lead to the following page.

ENcombi ADMIN  

Command timers 1

Start day:	Mon-Sun
Start hour:	18 h
Start minute:	0 min
Stop hour:	6 h
Stop minute:	0 min

Command timer setup page.
 Here the command timer period can be defined using the command time start and command time stop settings. The output will be placed in modbus.

2022-07-14-11:51:37

It is possible to set up 4 command timers. Type in the start day and time and stop time for the command timer. The output will be available on modbus and can be used for EClodic status/commands.

Command panel

The command panel holds 16 configurable command buttons and 16 status indicators. By clicking on the command panel icon, it will lead to the following page where the associated text strings for the 16 buttons and indicators can be typed in.

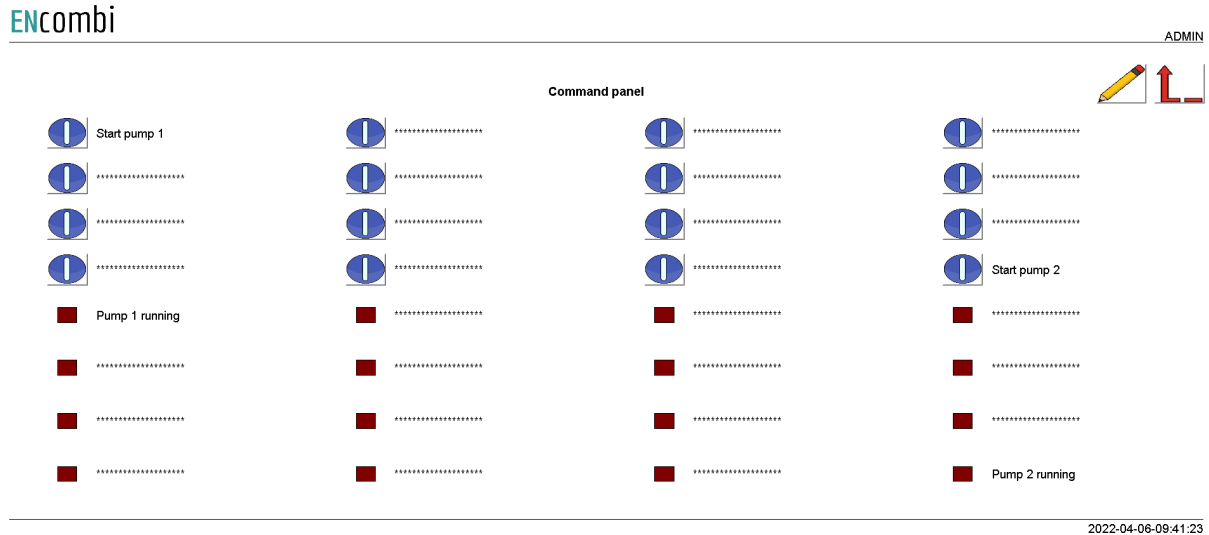

The actual functionality of the command panel is set up in the Builder/Linker using the addresses below.

31007	BITFIELD_7	16 unsigned int	Command Panel buttons 01..16	
29005	Cmd panel LED01..16: Green	16 unsigned int	bitwise	Not defined
29006	Cmd panel LED01..16: Red	16 unsigned int	bitwise	Not defined

Monitoring

The ECweb provides a high level overview of the installation as well as detailed information about each slave. Below is an example of the first page presented under the Monitoring tile.

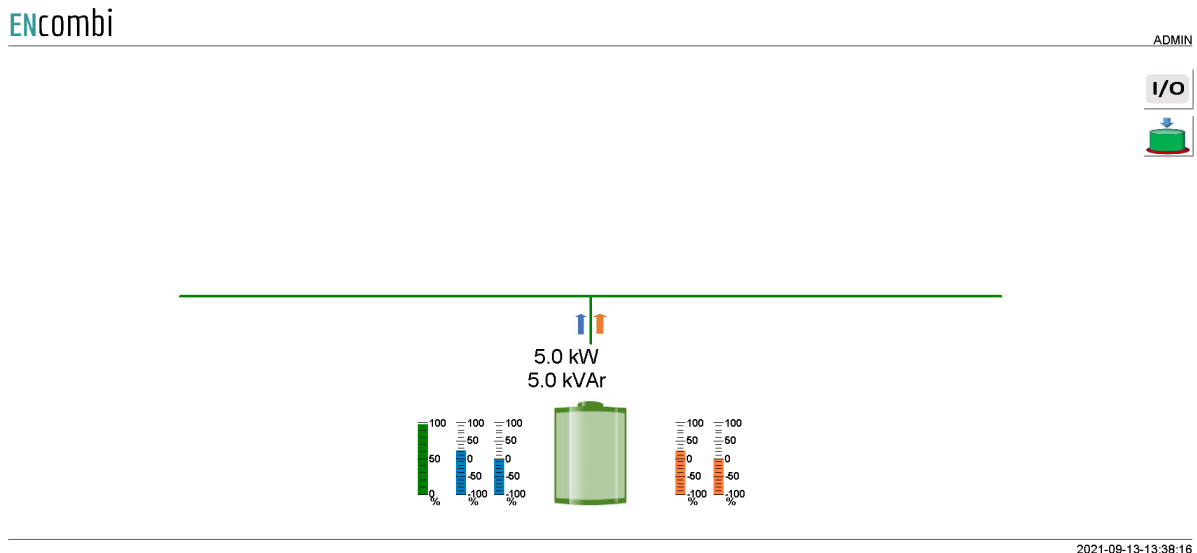

In case the battery symbol is neither gray nor green it means that the start signal is not present. In case the battery symbol is green it means that the start signal is present.

Blue and orange arrows indicate active power and reactive power flow direction respectively.

On the left hand side of the sources two blue bar graphs are shown. The one to the left shows the active power loading of the source in percentage. The one to the right shows the deviation from the active power reference in percentage.

On the right hand side of the sources two orange bar graphs are shown. The one to the left shows the reactive power loading of the source in percentage. The one to the right shows the deviation from the reactive power reference in percentage.

In the upper right corner four buttons are shown.

1. Command panel
2. IO module data.

Command panel

Clicking the command panel button will lead to the page below where the button commands and status indications are displayed.

Command panel

The command panel displays two pumps. Pump 1 has a 'Start pump 1' button (blue circle with a white bar) and a 'Pump 1 running' indicator (green square). Pump 2 has a 'Start pump 2' button (blue circle with a white bar) and a 'Pump 2 running' indicator (red square). Below these are two columns of buttons for each pump, each consisting of a blue circle with a white bar and a black square, representing various control and status elements.

IO module data

Clicking the IO module button will lead to the below page where an overview of all the readings from the IO modules is provided. In case a reading is not supported or communication to the IO module is failing, the readings will be displayed as "N.A".

IO modules	IO type	IO inputs	IO outputs	Communication state:	Communication enable:
IO 1:	EX1600DD	0000 0000 0000 1000	N.A		
IO 2:	EX1608DD	0000 0000 0001 0000	0000 0000 0000 0000		
IO 3:	OFF	N.A	N.A	N.A	N.A
IO 4:	OFF	N.A	N.A	N.A	N.A

Service Tool

First page to be displayed after an initial welcome page when switching to the Service Tool application is the front page of ECweb.

ENcombi



Select your category



2020-07-26-10:57:51

Navigating around in the Service Tool is done in the same manner as in the ECpvX Cluster application.

In the lower center two menu tiles are available. These are from the left:

1. "Identifiers" gives access to an overview of the SW version installed as well as to the menu for switching between the applications.
2. "Settings" give access to the set up of various features.

In the following chapters the content of the two menu tiles are discussed in detail.

Identifiers

Under this tile overview of SW version installed and extras present in the ECpvX cluster as well as to the menu for switching between the applications.

ENcombi

Company:					
Name:	Website:	Contact:	Support:	Cloud service:	
ENcombi	www.encombi.com	sales@encombi.com	support@encombi.com	www.encombi.online	
Product:					
Type:	Extras:	Project version:	Serial number:		
ECpvX Service Tool	-C-L-	1.00.0	202105040001		
Platform:					
Device type:	Device variant:	Chip type:	Rtos:	Version:	
WP240X	COM	SC24	V2.07 FULL	V23.9.63.1	
Identifiers:					
Serial number 1:	Serial number 2:	MAC address:			
14738AC71464B148	37648890F9A0D012	003056914973			

2021-09-20-14:22:53

On the right hand side there are one submenu for.

1. Application switch.

Application

Clicking the Application button leads to the page below. Here it can be selected which application is to be active.

ENcombi

Application		
Application:	ECPVX CLUSTER	
<p>Application swap page. Here it is set up which application to run. When toggling between applications, the device is to be reboot. Any settings made in the ECpvX application will be lost in the process. Store a backup before leaving the ECpvX project if any settings are made that is to be restored when reverting to the ECpvX Cluster application. Browser needs refreshing when the device has rebooted.</p>		

2021-09-13-14:18:10

The following applications are available.

1. ECpvX Cluster.
2. ECpvX Cluster Service Tool.
3. ECpvX Cluster Boot.

ECpvX Cluster is the default application and the one to use for the normal operation of the ECpvX Cluster. ECpvX Cluster Service Tool is a separate application that offers various tests and configuration features and the ECpvX Cluster Boot is a tool for updating both the ECpvX Cluster and the ECpvX Cluster Service Tool SW.

When toggling between applications the device is to be rebooted. Any settings made in the ECpvX Cluster application will be lost in the process. Make a backup before leaving the ECpvX Cluster application if any settings are made that are to be restored when reverting to the ECpvX Cluster application once again. The browser needs refreshing when the device is rebooted after switching the application.

Settings

Under this tile the setup of various features are found.

First page presented when clicking the Settings tile is the below page where COM2 configuration is set up.

ENcombi

COM2 port

Baudrate:	19200
Parity:	NO PARITY 1 STOP BIT
Timeout:	1.0 s
TX rate:	1.0 s
Slave ID:	1



COM2 Port setup page.
Baudrates supported are 9600, 19200, 38400 and 115200.

Power meter RTU communication is fixed on COM2.
Sensor and IO module RTU communication is optional on COM2.
In case none of these communications are enabled, COM2 is serving as a Modbus RTU slave.

Slave ID is only used in case COM2 is serving as a slave.



2021-09-13-14:19:24

Baud rates supported are:

- 9600, 19200, 38400 and 115200

Parity supported are:

- "Parity one stop bit", "No parity", "Even parity" and "Odd parity".

On the same menu level, a similar setup page for COM3 configuration is found. Clicking the up/down arrows will lead to it.

On the right hand side there are two submenus for.

1. IO modules
2. Modbus Tester.
3. Client Trace.

IO configuration

IO configuration allows you to read and write the configurations of IO modules over Modbus. Clicking the IO button leads to the page below where COM2 or COM3 can be selected.

IO modules

COM port: COM2



IO module setup page.
IO module communication can either run Modbus RTU or Modbus TCP.
Whether to use COM2, COM3 or TCP is selectable by parameter.
Port settings is setup at dedicated port setup page.



2021-09-20-14:29:30

Afterwards clicking on the IO configuration button on the right hand side leads to the IO configuration page.

IO module comm.

Baudrate: 9600
Parity: EVEN PARITY
Modbus ID: -
Timeout: -

IO module search

Modbus ID:
Module: N.A.
FW version: N.A.



Overdigit IO module communication setup page.
After IO module is powered up, then press the PG button on the IO module for 3s until the green LED starts flashing. Now the IO module is in a temporary state having the Baudrate and Parity listed in the colored Active Column. Note that the COM port selected for IO module communication must be configured accordingly to complete the configuration successfully. In the update column the requested communication setup is made and Save button is pushed to write it to the IO module. Afterwards, press the PG button again to stop the green LED flashing and activate the communication setup just made.
The Timeout determines the delay for no communication being active before the IO module releases all its relays. Setting it to "0 x 10ms" means disabling the functionality and the IO module will keep the relays at there states in case of communication loss.
Search a Modbus ID to find module type and firmware version.



2022-02-07-14:32:39

It is possible to set up the Overdigit IO module with the tool.

After the IO module is powered up, then press the PG button on the IO module for 3s until the green LED starts flashing. Now the IO module is in a temporary state, having the Baudrate and Parity listed in the colored Active Column. Note that the COM port selected for IO module communication must be configured accordingly to complete the configuration successfully. In the update column the requested communication setup is made and the Save button is pushed to write it to the IO module. Afterwards, press the

PG button again to stop the green LED flashing and activate the communication setup just made.

The Timeout determines the delay for no communication being active before the IO module releases all its relays. Setting it to "0 x 10ms" means disabling the functionality and the IO module will keep the relays at their states in case of communication loss.

AIO

When pressing the settings icon, it will lead to the following page.

ENcombi

EX04AIO config

Channel 1 type:	OFF
Channel 1 source:	0-10V
Channel 2 type:	OFF
Channel 2 source:	0-10V
Channel 3 type:	OFF
Channel 3 source:	0-10V
Channel 4 type:	OFF
Channel 4 source:	0-10V
Modbus ID:	-



Overdigit AIO module communication setup page.
 Here an EX04AIO can be set up.
 It is optional which port to use. It is setup at dedicated COM page.
 Port settings is setup at dedicated port setup page.
 Setup input and output for all 4 channels.
 Modbus ID needs to be set in order to write configuration.

2022-02-07-14:34:29

From there it is possible to set up an EX04AIO module. From here it is selectable which channel to use for input and output. All 4 channels can be selected as off, input and output. It is also selectable which source the input or output should work with. The two options are 0-10 or 4-20mA. When the configuration is ready, the modbus ID must be set and after that it is possible to write the configuration to the module. An icon will show if the writing was successful or failed.

Toggle to the next page will lead to the set up of EX04AIS.

ENcombi

EX04AIS config

Channel 1 source:	OFF
Channel 2 source:	OFF
Channel 3 source:	OFF
Channel 4 source:	OFF
Modbus ID:	-



Overdigit AIS module communication setup page.
 Here an EX04AIS can be set up.
 It is optional which port to use. It is setup at dedicated COM page.
 Port settings is setup at dedicated port setup page.
 Setup input for all 4 channels.
 Modbus ID needs to be set in order to write configuration.

2022-02-08-09:42:21

These are only inputs, so the only configuration is which source the channels should be. It can also be selected as OFF, which means the channel is deactivated.

Modbus Tester

Modbus Tester is a feature where the Service Tool acts as a Modbus RTU Master and communication with a Modbus RTU Slave can be tested. Clicking the Modbus Tester button leads to the page below where it is set up whether the Modbus Tester is to use COM2 or COM3.

ENcombi

Modbus tester

COM port: COM2



Modbus test page.
Here read and write commands can be tested.
The Modbus tester is for Modbus RTU only.
Whether to use COM2 or COM3 is selectable by parameter.
Port settings is setup at dedicated port setup page.



2020-07-26-11:17:56

Afterwards, clicking on the Modbus Tester button on the right hand side leads to the Modbus Tester itself where Modbus RTU read and write commands of various length and function codes can be transmitted and the response received is shown.

ENcombi

Read

Start ID: 1 Stop ID: 1 Control Fnc: 0x03 Control Fnc: 16BIT Control Fnc: SIGNED Address: 0 Length: 1

N.A	N.A	N.A	N.A	N.A	1	N.A
Register 1..2	Register 3..4	Register 5..6	Register 7..8	Register 9..10	Byte 01..20	

Write

Modbus ID: 1 Control Fnc: 0x06 Control Fnc: 16BIT Control Fnc: SIGNED Address: 0 Command: 0

UNICAST

N.A

2022-03-11-14:56:43



Client trace

Clicking the Client Trace button leads to the page below where trace of Modbus communication can be enabled/disabled. The Modbus Tester only shows the result/content of valid Modbus frames received. The Trace, on the other hand, provides information on any communication being detected on the RS485 line even if it is not perceived as valid Modbus frames.

ENcombi

Trace

Modbus: DISABLED

Trace setup page.
Enabling/disabling trace of various device client activities.
Trace is readable via device Telnet server.

2020-07-26-11:35:57

Trace is available via the built-in Telnet server. Clicking on the Telnet server button on the right hand side leads to the Telnet server setup.

Telnet server

On the page below the telnet server access is set up.

ENcombi



ADMIN

TELNET Server:

User0: telnet_user0

Password0: *****

Telnet: ENABLED

Telnet server setup page.
Credential is for device telnet server access.
Telnet is usable for tracing various device client activities.

2020-07-10-13:14:30

Use the PC application "Chiptool" to connect to the Telnet Server to follow activities such as the Modbus trace.

Boot

First page to be displayed after an initial welcome page when switching to the Boot application is the front page of ECweb.

ENcombi



Select your category



2021-02-02-13:42:34

Navigating around in the Service Tool is done in the same manner as in the ECpvX Cluster application.

In the lower center one menu tile is available:

1. "Identifiers" gives access to an overview of the SW version as well as to the menus for updating SW and switching between the applications.

In the following chapters the content of the menu tile is discussed in detail.

Identifiers

Under this tile overview of SW version installed and extras present in the ECpvX.

ENcombi

Company:

Name:	Website:	Contact:	Support:	Cloud service:
ENcombi	www.encombi.com	sales@encombi.com	support@encombi.com	www.encombi.online



Product:

Type:	Extras:	Project version:	Serial number:
ECpvx Cluster Boot	-C-	1.00.0	202205200001

Platform:

Device type:	Device variant:	Chip type:	Rtos:	Version:
WP240X	COM	SC24L	V2.07 FULL	V23.9.63.1

Identifiers:

Serial number 1:	Serial number 2:	MAC address:
C3DD7428B3FA5D66	0B0FAB92B7B8BA18	026109610B20

2021-09-13-15:21:08

On the right hand side there are submenus for.

1. SW update.
2. Application switch.

SW update

Clicking the SW update button leads to the page below. From here the ECpvX Cluster and the ECpvX Cluster Service Tool SW can be updated from a USB stick.

ENcombi



Device project update via USB.

- 1: Create an empty folder on your laptop named ECpvx_cluster_SW.
- 2: Download the SW file from the website.
- 3: Unzip the downloaded file.
- 4: Navigate to the SW version folder.
- 5: Copy the content of the SW version folder.
- 6: Paste the content to the ECpvx_SW folder.
- 7: Copy the ECpvx_SW folder to the root of a USB stick.
- 8: Insert USB stick into the device.
- 9: Click the search for SW button.
- 10: Wait for the process to complete.
- 11: If completed successfully then revert to the ECPVX CLUSTER application.



2021-09-13-15:25:35

Download the SW from the website and place it in a folder named "ECpvx_Cluster_SW" in the root of a USB stick like shown below:

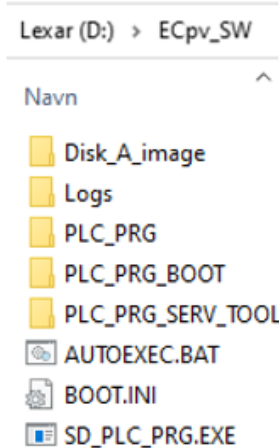

Then insert the USB stick into the ECpvX Cluster and press the binoculars button to start the SW update. When the SW update is completed successfully, then you can safely revert to the ECpvX Cluster application. If the SW is interrupted and it fails, then remain in the Boot application and try to update the SW once again. Do not return to the ECpvX Cluster application until the SW update is completed successfully.

Application

Clicking the Application button leads to the page below. Here it can be selected which application is to be active.

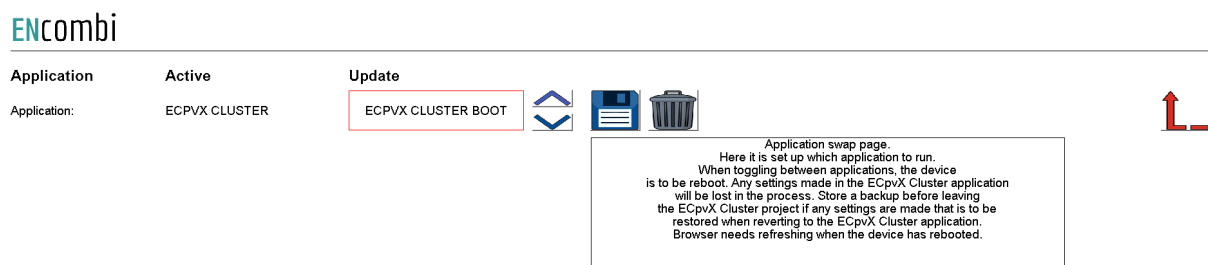

2021-09-13-15:26:07

The following applications are available.

1. ECpvX Cluster.
2. ECpvX Cluster Service Tool.
3. ECpvX Cluster Boot.

ECpvX Cluster is the default application and the one to use for the normal operation of the ECpvX Cluster. ECpvX Cluster Service Tool is a separate application that offers

various tests and configuration features and the ECpvX Cluster Boot is a tool for updating both the ECpvX Cluster and the ECpvX Cluster Service Tool SW.

When toggling between applications the device is to be rebooted. Any settings made in the ECpvX Cluster application will be lost in the process. Make a backup before leaving the ECpvX Cluster application if any settings are made that are to be restored when reverting to the ECpvX Cluster application once again. The browser needs refreshing when the device is rebooted after switching the application.